



**KILLARK®**

## INSTALLATION, OPERATION & MAINTENANCE DATA SHEET

**“XCS-OK” SERIES SPRING RETURN SELECTOR SWITCH ASSEMBLIES  
(KEY OPERATED)  
CLASS I, GROUPS C & D CLASS II, GROUPS E, F, & G  
CLASS III HAZARDOUS LOCATIONS**



## “XCS-OK” SERIES SPRING RETURN SELECTOR SWITCH ASSEMBLIES

### **CAUTION:**

Before installing, make sure you are compliant with area classifications, failure to do so may result in bodily injury, death and property damage. Do not attempt installation until you are familiar with the following procedures. All installation must comply with the applicable Electrical Code.

Make sure that the circuit is de-energized before starting installation or maintenance.

Verify that the installation is grounded. Failure to ground will create electrical shock hazards, which can cause serious injury and or death.

Technical information, advice and recommendations contained in these documents is based upon information that Killark believes to be reliable. All the information and advice contained in these documents is intended for use only by persons having been trained and possessing the requisite skill and know-how and to be used by such persons only at their own discretion and risk. The nature of these instructions is informative only and does not cover all of the details, variations or combinations in which this equipment may be used, its storage, delivery, installation, check out, safe operation and maintenance. Since conditions of use of the product are outside of the care, custody and control of Killark, the purchaser should determine the suitability of the product for his intended use, and assumes all risk and liability whatsoever in connection therewith.

**KILLARK®**

**Chalmit**

**Victor**  
Lighting

**Vantage**  
Technology

**RIG POWER**

**HAWKE**  
International

3940 Dr. Martin Luther King Drive  
St. Louis, MO 63113

P/N 00901307 FORM NO. K0565 R09/08 ECO-3-038-08

Page 1 of 5

**CAUTION:** Before beginning installation, make sure that the supplying circuit is turned **OFF**.

Be sure the flame paths (cover to box mating surfaces and threaded openings) do not become damaged.

Do not install in a corrosive area which will attack the “copper free” aluminium alloys or stainless steel shaft unless the casting and parts have been protected against the specific corrosive environment.

Do not locate in areas where dust, ice, snow, or other substance will accumulate and thereby impair the rotary operation of the device.

XCS-0K device are for surface mounting in hazardous atmospheres as defined by NEC article 500. They contain an electrical device and must be sealed from the conduit system as required by article 501-5. Type “ENY”, “EY” or “EYS” series (or equivalent).

## **1. DIRECTIONS FOR INSTALLATION**

Install sealing fitting as required in class I & II areas. (Note: for class I (5) and Class II (3-1/2) full threads engagement are required).

The conduit threads should be lubricated with a non-electrical insulating lubricant, or pipe joint compound which will not promote corrosion or chemically attack aluminium.

After the conduit system has been properly installed, pull the wires and make the electrical connections as required. The electrical circuits and ground continuity should be checked with an instrument approved for the area.

Flame path machined on cover & box such that a 0.0015” Feeler gauge will not enter more than 1/8” when fully assembled & bolted to box – care must be taken that surface is not damaged.

If keyed alike is required substitute the letter “A” for “D” at the end of the catalog number. Key removable in locked position.

## **2. OPERATION**

The mechanical action of these devices is rotary.

The electrical action is dependent upon the cam configuration and the contact block used (see chart). The key is removable in the locked position.

## **3. MAINTENANCE**

The shaft should be lubricated occasionally to prevent binding. Use Killark “LUBG” (general purpose) or Killark “LUBT” (high temperature) lubricants.



XCS KEY OPERATED SPRING RETURN SELECTOR SWITCH				XCS - 0K ARE HEAVY DUTY,			
Two Position Spring Return Left				600 VAC RATED.			
<b>CATALOG NUMBER</b>				<b>TWO POSITION DIAGRAM</b>			
COVER WITH DEVICE	COMPLETE UNITS (BOX & COVER)			LEFT POSITION		RIGHT POSITION	
	DEAD - END	FEED - THRU		LEFT BLOCK	RIGHT BLOCK	LEFT BLOCK	RIGHT BLOCK
XCS-0K2L3F22D	XCS-42K2L3F22D	XCS-45K2L3F22D					

KEY OPERATED SPRING RETURN SELECTOR SWITCH									
Three Position Spring Return to Center From Right, Maintain in left									
<b>CATALOG NUMBER</b>				<b>THREE POSITION DIAGRAM</b>					
COVER WITH DEVICE	COMPLETE UNITS (BOX & COVER)			LEFT POSITION		CENTER POSITION	RIGHT POSITION		
	DEAD - END	FEED - THRU		LEFT BLOCK	RIGHT BLOCK	LEFT BLOCK	RIGHT BLOCK	LEFT BLOCK	RIGHT BLOCK
XCS-0K3L6G32D	XCS-42K3L6G32D	XCS-45K3L6G32D							

XCS KEY OPERATED SPRING RETURN SELECTOR SWITCH									
Three Position Spring Return to Center From Right or Left									
<b>CATALOG NUMBER</b>				<b>THREE POSITION DIAGRAM</b>					
COVER WITH DEVICE	COMPLETE UNITS (BOX & COVER)			LEFT POSITION		CENTER POSITION	RIGHT POSITION		
	DEAD - END	FEED - THRU		LEFT BLOCK	RIGHT BLOCK	LEFT BLOCK	RIGHT BLOCK	LEFT BLOCK	RIGHT BLOCK
XCS-0K3M6G32D	XCS-42K3M6G32D	XCS-45K3M6G32D							

XCS KEY OPERATED SPRING RETURN SELECTOR SWITCH									
Three Position Spring Return to Center From Left, Maintain in Right									
<b>CATALOG NUMBER</b>				<b>THREE POSITION DIAGRAM</b>					
COVER WITH DEVICE	COMPLETE UNITS (BOX & COVER)			LEFT POSITION		CENTER POSITION	RIGHT POSITION		
	DEAD - END	FEED - THRU		LEFT BLOCK	RIGHT BLOCK	LEFT BLOCK	RIGHT BLOCK	LEFT BLOCK	RIGHT BLOCK
XCS-0K3R6G32D	XCS-42K3R6G32D	XCS-45K3R6G32D							

XCS TWO POSITION KEY OPERATED SELECTOR SWITCH (MAINTAINED)							
<b>CATALOG NUMBER</b>				<b>TWO POSITION DIAGRAM</b>			
COVER WITH DEVICE	COMPLETE UNITS (BOX & COVER)			LEFT POSITION		RIGHT POSITION	
	DEAD - END	FEED - THRU		LEFT BLOCK	RIGHT BLOCK	LEFT BLOCK	RIGHT BLOCK
XCS-0K2A1D	XCS-1K2A1D	XCS-4K2A1D					
	XCS-2K2A1D	XCS-5K2A1D					
XCS-0K2A5D	XCS-42K2A5D	XCS-45K2A5D					



3940 Dr. Martin Luther King Drive  
St. Louis, MO 63113

P/N 00901307 FORM NO. K0565 R09/08 ECO-3-038-08

XCS THREE POSITION KEY OPERATED SELECTOR SWITCH (MAINTAINED)								
CATALOG NUMBER			THREE POSITION DIAGRAM					
COVER WITH DEVICE	COMPLETE UNITS (BOX & COVER)		LEFT POSITION		CENTER POSITION		RIGHT POSITION	
	DEAD - END	FEED - THRU	LEFT BLOCK	RIGHT BLOCK	LEFT BLOCK	RIGHT BLOCK	LEFT BLOCK	RIGHT BLOCK
XCS-0K3C4D	XCS-1K3C4D	XCS-4K3C4D						
	XCS-2K3C4D	XCS-5K3C4D						
XCS-0K3C5D	XCS-42K3C5D	XCS-45K3C5D						

ITEM NO.	XCS.OK SERIES P/N	QTY	DESCRIPTION
1	17900AAAB	1	GO SHORT STYLE OPERATOR BODY
2	0611300B	1	1/8X5/8SS SPRING PIN
3	17969ABAM	1	XCS-OK/OS COVER
4	17791AAAB	SEE BOM	2-POS. MAINTAINED PLATE
	17791BAAB		3-POS. MAINTAINED PLATE
5	0309052B	1	11605 GASKET
6	08212ABHB	1	8212 KNOB-SHAFT ASSY
7	17786AAAB	1	SELECTOR SWITCH INDEX SPRING
8	0103249B	1	S-217-1 BALL CGE LEVER
9	0682425B	1	W-T 5100-31 RETAINING RING
10	LN2	1	3/4 STEEL LOCKNUT (UL)
11	0608130B	1	10385 SPACER PLATE
12	16504AAAB	3	6-32X.375 BH NP SCREW
13	0860750B	2	6 EXT TH LOCKWASHER
14	0106775B	SEE BOM	2-POS. "A" CAM (8505)
	0106600B		3-POS. "B" CAM (11586)
	0106500B		3-POS. "C" CAM (11587)
	0106550B		3-POS. "D" CAM (11588)
	0106650B		3-POS. "E" CAM (11589)
	0106750B		3-POS. "G" CAM (11590)
15	0860650B	1	6 SPLIT LOCKWASHER
16	0860751B	1	6 FLAT WASHER
17	17875AAAB	SEE BOM	3-POS COLLAR, KEY REMOVE ALL
	17875BAAB		2-POS COLLAR, KEY REMOVE BOTH
	17875CAAB		3-POS COLLAR, KEY REMOVE CENTER
	17875DAAB		2-POS COLLAR, KEY REMOVE L/R
18	17820BAAB	1	KEY LOCK RETAINER WASHER
19	16104AAAB	1	LOCK, KEYED ALIKE
	16104BAAB		LOCK, KEYED DIFFERENT
20	17876AAAB	1	G SERIES KEY CAP
21	14510WHB	3	6-32 X1/8 SS KNPT SET SCREW
22/23	0226100B	SEE BOM	CONTACT BLOCK, NORM. OPEN
	0226200B		CONTACT BLOCK, NORM. CLOSED
	0226300B		CONTACT BLOCK, N.O EARLY MAKE
	0226075B		CONTACT BLOCK, N.C LATE BREAK
24	0540051B	1	COMPONENT NAMEPLATE
25	14242AADB	1	COMPONENT NAMEPLATE
26	0547320B	SEE BOM	G SERIES NAMEPLATE
	0547330B		G SERIES NAMEPLATE
27	12140Aafb	1	NAMEPLATE
28	16489AAAB	8	#2X. 188 SL PAN HD SCREW
29	00891896	1	COVER SCREW SUBASSEMBLY



3940 Dr. Martin Luther King Drive  
St. Louis, MO 63113

P/N 00901307 FORM NO. K0565 R09/08 ECO-3-038-08

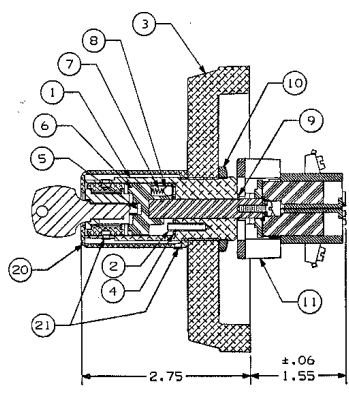
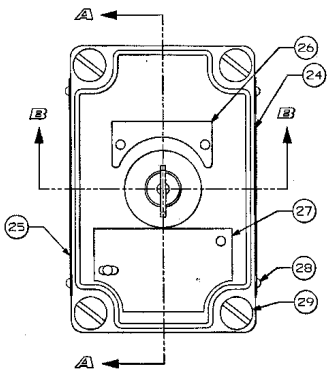

**SECTION A\*A**

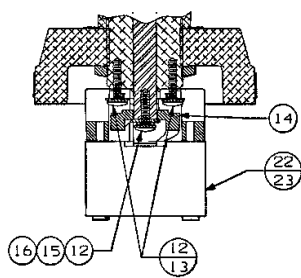

**SECTION B\*B**